

Nr	Xmm	Ymm	Zmm	x
A	550	411	16	1
B	550	411	16	1
C	1668	410	16	1
D	1668	410	16	1
E	517	379	16	1
F	511	400	16	1
G	511	600	22	1

Nr	Xmm	Ymm	Zmm	x
H	509	724	4	1
I	515	364	4	1
J	516	364	16	1
K	538	1688	2,5	1
L	517	379	16	1

<b>B1</b> 16x ø8x35	<b>K5</b> 16x 34mm	<b>K1</b> 16x ø15x12	<b>I20</b> 16x ø4/ø17	<b>W4</b> 62x	<b>L21</b> 1x
<b>G50</b> 6x 3,5x16	<b>I3</b> 6x	<b>I18</b> 1x ø14	<b>F2</b> 4x ø5	<b>F11</b> 4x ø5	<b>C4</b> 4x Z350D
<b>D4</b> 4x PZ350D	<b>G5</b> 8x 4x13	<b>P67</b> 4x h150	<b>G34</b> 18x 3,5x16	<b>J24</b> 1x L150	<b>S26</b> 2x ø6/16
<b>G37</b> 1x ø4x13	<b>G17</b> 1x 4x45	<b>U6</b> 1x ø8x40			

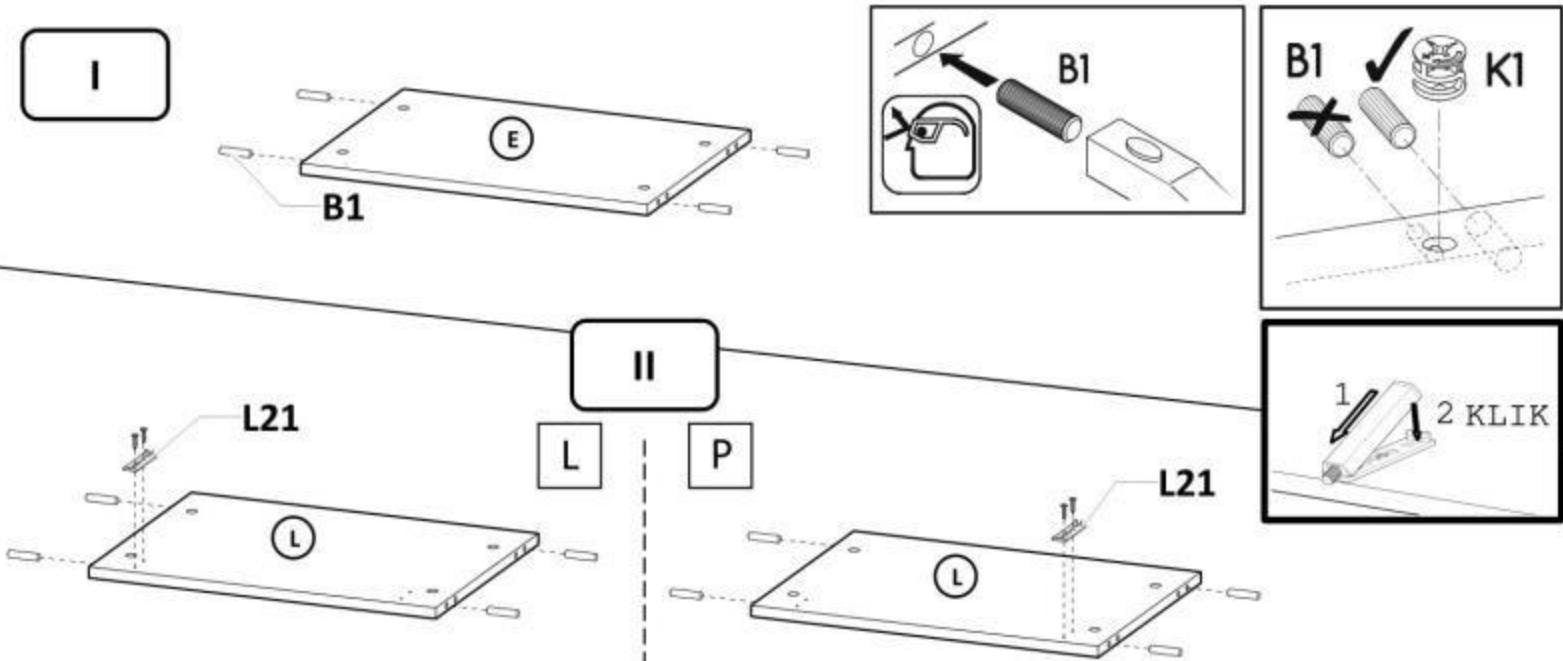

III

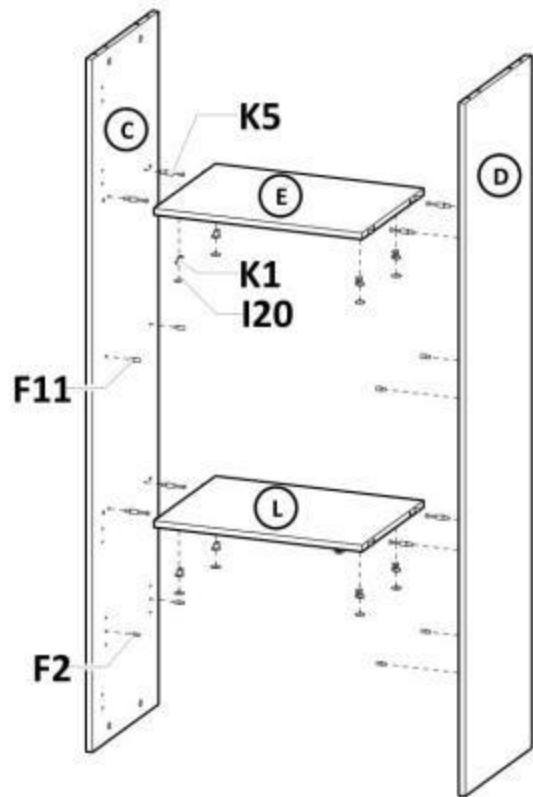

*i*

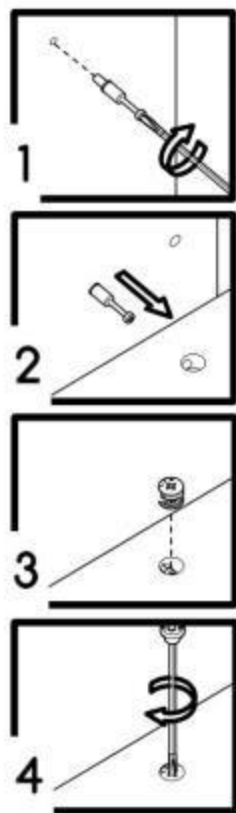

IV

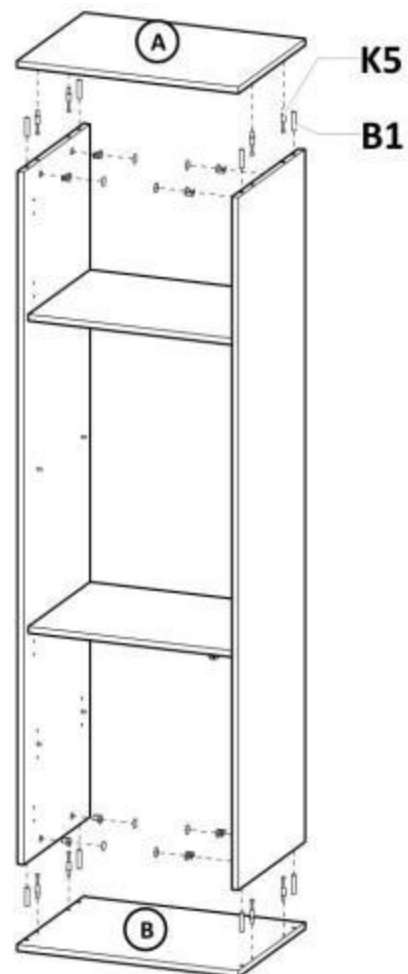

V

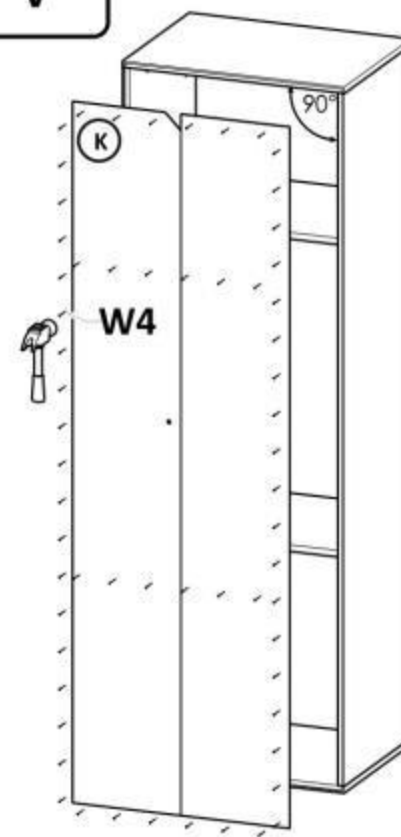

VI

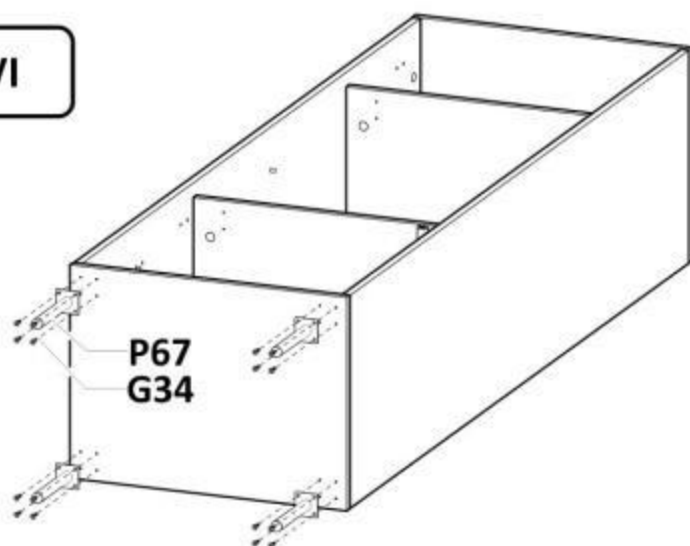

VII

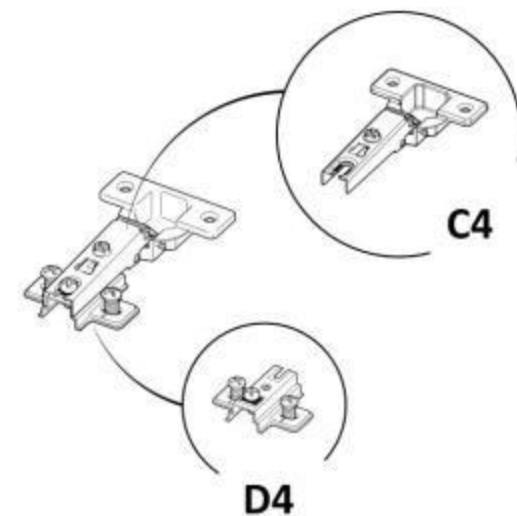
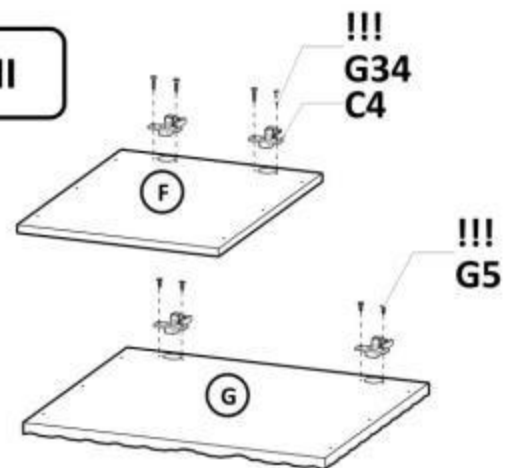

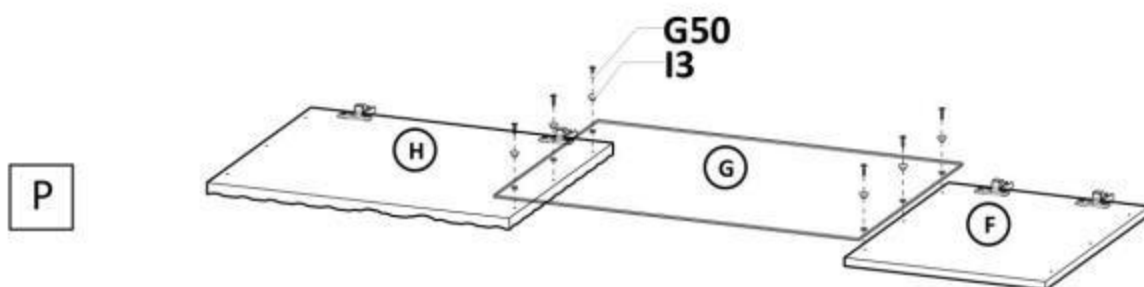

VIII

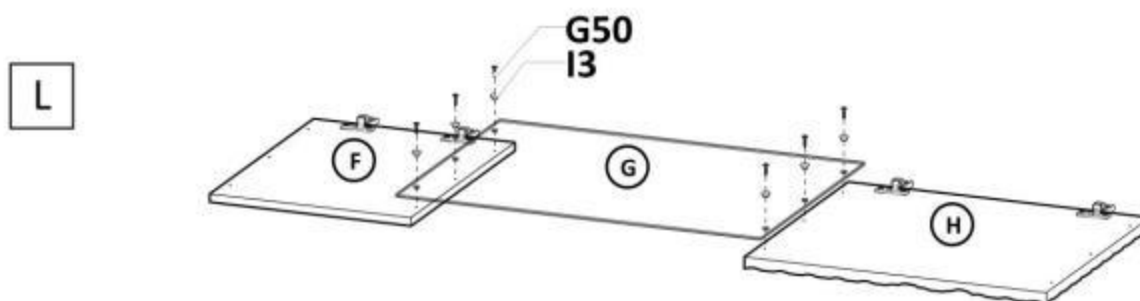

IX

L

P

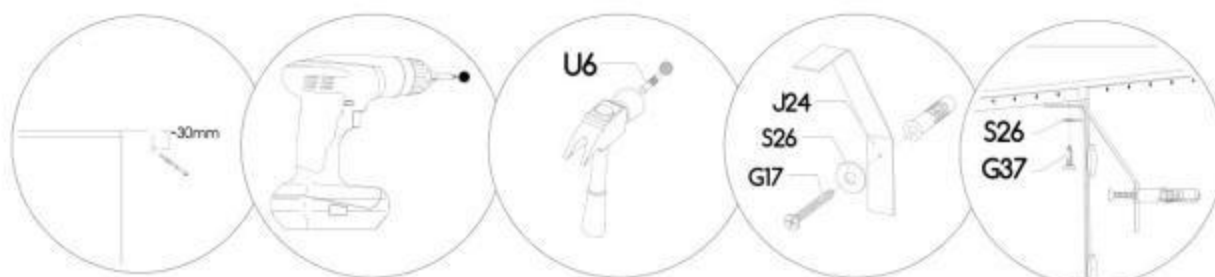
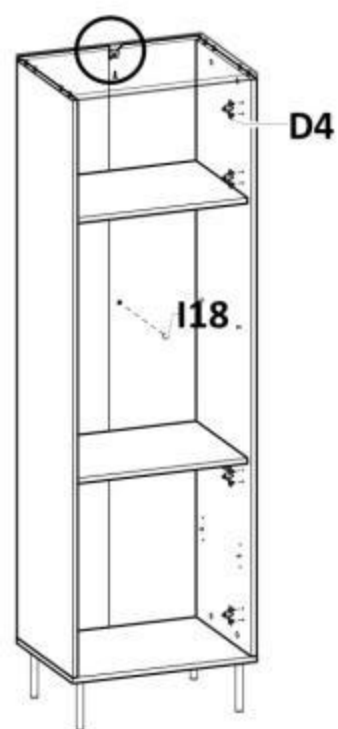

X

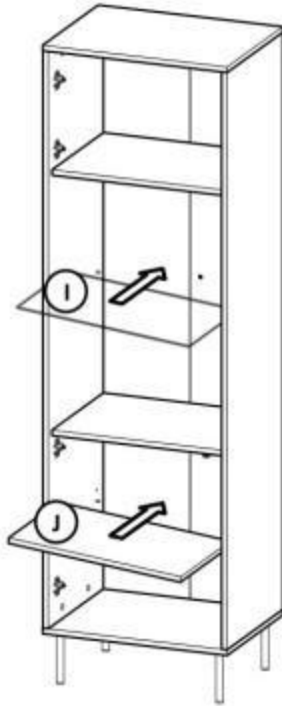

XI

L

P

